



INNOVATIVE: Journal Of Social Science Research

Volume 3 Nomor 6 Tahun 2023 Page 10258-10264

E-ISSN 2807-4238 and P-ISSN 2807-4246

Website: <https://j-innovative.org/index.php/Innovative>

The Effect Of Company Size, Asset Growth And Profitability On Capital Structure

Cindy Lingga Santi^{1✉}, Irma tyasari², Rita indah mustikowati³

Management Study Program, Faculty of Economics & Business,

University PGRI Kanjuruhan Malang

Email : cindylinggasanti1229@gmail.com[✉]

Abstract

The purpose of this research is to analyze company size, asset growth and profitability on capital structure. The population in this research is property and real estate companies listed on the IDX in 2019-2021. Purposive sampling technique was used to select the research sample and there were 22 companies that met the considerations and criteria. The hypothesis was tested using the classic assumption test, multiple linear analysis as well as the F test and t test. The results of this research indicate that company size, asset growth and profitability simultaneously influence capital structure. Therefore, the larger a company, the more funds it needs to support asset growth and the company can achieve high profitability without using excessive amounts of external capital so that company profits can be utilized effectively. Contributes to companies considering determining a good capital structure in funding decisions originating from external and internal sources.

Kata Kunci : *Company Size, Asset Growth, Profitability, Capital Structure*

Abstract

Tujuan penelitian ini adalah untuk menganalisis ukuran perusahaan, pertumbuhan aset dan profitabilitas terhadap struktur modal. Populasi dalam penelitian ini adalah perusahaan property dan real estate yang terdaftar di BEI tahun 2019-2021. Teknik purposive sampling digunakan untuk memilih sampel penelitian dan terdapat 22 perusahaan yang memenuhi pertimbangan dan kriteria. Hipotesis diuji dengan menggunakan uji asumsi klasik, analisis linier berganda serta uji F dan uji t. Hasil penelitian ini menunjukkan bahwa ukuran perusahaan, pertumbuhan aset dan profitabilitas secara simultan berpengaruh terhadap struktur modal. Oleh karena itu, semakin besar suatu perusahaan maka semakin banyak dana yang dibutuhkan untuk menunjang pertumbuhan aset dan perusahaan dapat mencapai profitabilitas yang tinggi tanpa menggunakan modal eksternal yang berlebihan sehingga keuntungan perusahaan dapat dimanfaatkan secara efektif. Berkontribusi pada perusahaan mempertimbangkan penentuan struktur modal yang baik dalam keputusan pendanaan yang berasal dari sumber eksternal dan internal.

Keyword: *Ukuran Perusahaan, Pertumbuhan Aset, Profitabilitas, Struktur Modal*

INTRODUCTION

All aspects of social and industrial life are affected by the rapid development of the times. The property and real estate industry is one of the most competitive businesses in Indonesia. Based on information from the Census and Economic Center, property growth reached 5.76% in 2019 before declining to 2.32% in 2020 and the following year increased to 3.78%. After the covid-19 outbreak that hit Indonesia, this data still shows positive changes in the property industry. According to (detikfinance, 2020) reported that over the past three years the growth of the property sector has only increased by around 3.5%, lower than the national economic growth rate of around 5%. Due to the slow development of the industry, companies in the property and real estate sector need to pay attention to their capital structure in order to meet investment needs.

Capital structure is a very important thing for companies to pay attention to, so that the company can guarantee the continuity of its business. With a good and optimal capital structure, a company can maximize the value of its business because it has a level of risk and a level of return in balance.

In general, capital structure is a ratio to assess the proportion of long-term debt to equity. The company's financial condition will be influenced by the capital structure so this is important to pay attention to (Rico Andika & Sedana, 2019).

There are several factors that influence the capital structure of a company, namely tax burden,

asset growth, company size and profitability, all of which are very important factors for all companies to pay attention to in order to maintain the sustainability of their business. In this study, researchers used factors that influence the structure. capital includes asset growth, company size, and profitability. Company size is an important factor that can influence a company's capital structure, where the size of a company can be expressed in company size, which means that as total assets increase, the size of the company becomes larger (Hidayati et al., 2021). Next there is asset growth, one component of the capital structure that is no less important. Asset growth can have an influence on financing sources. The higher the asset growth of a company, the greater the capital structure it has. Asset growth is an asset that is used in the process operational (Cindy, 2020). Profitability is the next variable that can have an impact on capital structure. In summary, profitability is also a ratio to compare a company's ability to earn profits (Kasmir, 2014). This profitability also greatly influences the company's capital structure. The higher the company's profitability, the higher the company's capital structure. (Stekla, J., & Grycova, M, 2016)

The purpose of this research is to identify variables that influence capital structure, the larger the company size, the total assets obtained will increase, then asset growth will also increase so that the level of profit is also expected to be high so that the company can reduce the amount of funding from external parties to the company.

The following is the framework for thinking in research that has been processed by researchers:

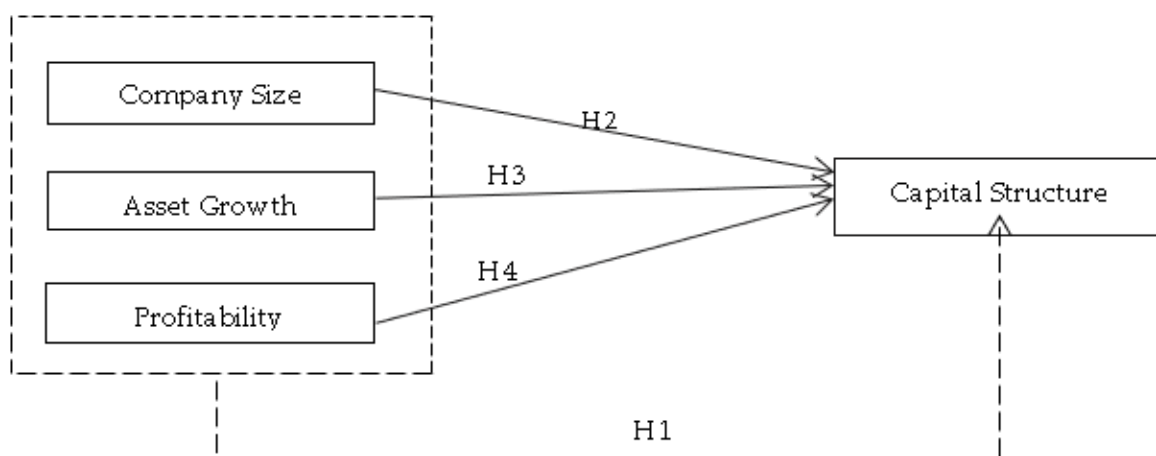

METHODS

This research design uses quantitative research using secondary data sources, namely property and real estate industry data listed on the IDX in 2019-2021. The aim of this research is to see the influence of company size, asset growth and profitability on capital structure. Purposive sampling is used as a sampling and analysis technique by utilizing multiple linear regression tests using SPSS 24 software.

RESULT AND DISCUSSION

From the results testing hypothesis influence direct between variable can be served in table following This :

Table 3.1
Results Testing hypothesis Influence between variable

Model		Coefficients ^a						
		Unstandardized Coefficients		Standardized Coefficients	t	Sig.	Collinearity Statistics	
		B	Std. Error	Beta			Tolerance	VIF
1	(Constant)	-.067	.028		-2.378	.021		
	X1 (Company Size)	.004	.001	.407	4.030	.000	.977	1.024
	X2 (Asset Growth)	.171	.061	.299	2.822	.006	.885	1.130
	X3 (ROE)	.275	.112	.260	2.459	.017	.890	1.123

a. Dependent Variable: Y (DER)

Source : SPSS 24

From table 3.1 _ can be explained as following :

$$Y = -0.067 + 0.004 X1 + 0.171 X2 + 0.275 X3 + e_i$$

The constant of -0.067 means that company size, asset growth and profitability are 0, then DER is -0.067. The regression coefficient of company size is 0.004. Therefore, if the company size increases by 1 unit, the DER increases by 0.004. Asset growth with a regression coefficient value of 0.171, means that if there is an increase of 1 unit in asset growth, DER increases by 0.171. Profitability with a regression coefficient of 0.275, which means that if there is an increase in profitability of 1 unit, then DER increases by 0.275.

1. Effect of Company Size, Asset Growth and Profitability on Capital Structure

The results of the F test for the variables Company Size, Asset Growth and Profitability have a probability value of $0.000 < 0.05$. So it can be concluded that H_0 is rejected and H_a is accepted, which means that simultaneously there is a significant influence of the variables company size, asset growth and profitability on capital structure. This means that as the size of the company increases, the funds required will also increase, as well as the increase in the level of asset growth, the operational costs required will also increase, therefore if the company obtains a high level of profitability then this is used as internal funds. originating from retained

earnings. These results are in line with previous research, namely according to Khoiriyah & Rasyid (2020) with the results that company size, asset growth and profitability influence capital structure.

2. Effect of Company Size on Capital Structure

can be concluded that H_0 is rejected and H_a is accepted, which means that company size has a significant and positive influence on capital structure. Therefore, if the size of the company increases, there will be an increase in the capital structure. These results are in line with research according to Sari & Agustin (2019) with the results that size has a significant and positive effect on capital structure.

3. Effect of Asset Growth on Capital Structure

The t test results for the Asset Growth variable have a probability value of $0.006 < 0.05$. So it can be concluded that H_0 is rejected and H_a is accepted. It can be concluded that Asset Growth has a significant and positive influence on Capital Structure. This means that if assets experience high growth, the use of external funds will increase because internal funds are insufficient to support the company's operational activities. These results are in line with previous research, namely according to Khoiriyah & Rasyid (2020) with the result that asset growth on capital structure has a positive and significant effect.

4. Effect of Profitability on Capital Structure

The t test results for the Asset Growth variable have a probability value of $0.017 < 0.05$. So it can be concluded that H_0 is rejected and H_a is accepted, which means that Profitability (ROE) has a significant and positive influence on Capital Structure. This reflects that the higher the profitability produced, it shows that the company can effectively and optimally manage its capital to gain profits and can be used as a source of internal funding for the company. This research is supported by previous research, namely according to Khoiriyah & Rasyid (2020) with the results that profitability on capital structure has a significant and positive influence on capital structure.

CONCLUSION

Based on the research results, it can be concluded as follows:

1. Simultaneously company size, asset growth and profitability have a significant effect on capital structure. So it can be concluded that determining funding must take into account the size of a company, the level of asset growth and the level of profitability of a company. The larger the company size, asset growth and profitability, the greater the capital structure.
2. Company size partially has a significant and positive influence on capital structure. The larger the company size, the greater the capital structure it has.

3. Partial asset growth has a positive and significant effect on capital structure. With good management, the greater the asset growth, the greater the capital structure.
4. Profitability has a significant and positive influence on Capital Structure. The higher the company's profitability, the higher its capital structure.

For companies, this research is expected to provide information to consider determining a good capital structure in funding decisions from external and internal sources. Furthermore, for investors, the results of this research can be used as a reference to find out several factors that influence capital structure and investment decisions. Future researchers can use other variables that can influence the company's capital structure.

REFERENCES

- Brigham, E. F. (2011). *Fundamentals of Financial Management*. Fourth Edition.
- Cindy, K. (2020). Pontjo Bambang Mahargiono College of Economics Indonesia (STIESIA) Surabaya.
- Dewiningrat A. I, & Mustanda, K. I. (2020). The Effect of Liquidity, Profitability, and Asset Growth on Capital Structure. *eCo-Buss*, 2(3), 18-31.
- Ghozali, I. (2018). *Application of Multivariate Analysis with IMB SPSS 25 Program*. Diponegoro University.
- Hidayati, A., Lakoni, I., & Seventeen, W. L. (2021). JUMPA Vol. 8 No. 3 October 2021 Analysis of Capital Structure Relationship Based on Trade Off Theory and Pecking Order Theory in the Banking Sector Listed on the LQ 45 Index. *Journal of Management and Banking (JUMPA)*, 8(3), 1-15.
- Kasmir. (2012). *Financial Report Analysis*. PT. Raja Grafindo Persada.
- Kasmir. (2014). *Financial Statement Analysis*. PT. Raja Grafindo Persada.
- Kasmir. (2016). *Financial Statement Analysis*. PT. Raja Grafindo Persada.
- Khoiriyah, D., & Rasyid, R. (2020). The Effect of Business Risk, Profitability and Asset Growth on the Capital Structure of Companies Listed on the Jakarta Islamic Index. *Journal of Management and Entrepreneurial Studies*, 2(2), 43.
- Rico Andika, I. K., & Sedana, I. B. P. (2019). The Effect of Profitability, Asset Structure, and Company Size on Capital Structure. *E-Journal of Management*, Udayana University, 8(9), 5803.
- Sari, M. A., & Agustin, S. (2019). The Effect of Company Size, Profitability and Asset Growth on Capital Structure in Property Companies on the IDX. *Journal of Management Science and Research*, 8(2), 1-18.
- Stekla, J., & Grycova, M. (2016). The relationship between profitability and capital structure of

agricultural holdings in the Czech Republic. *Agricultural Economics (Czech Republic)* , 62 (9), 421–428. <https://doi.org/10.17221/232/2015-AGRICECON>

Sulistiono, H., & Anggra, E. (2017). Sulistiono, H., & Anggra, E. (2017). The Effect of Asset Structure, Company Size, Asset Growth, and Profitability on Capital Structure in Telecommunication Companies on the IDX for the 2013-2015 Period. *Permana*, 8(1), 69-80.

Suryani Fajrida, N. M. B. P. (2020). The Effect of Profitability, Company Size and Asset growth on Capital Structure in Companies on the Indonesia Stock Exchange. *EMBA Journal: Journal of Economic Research, Management, Business and Accounting*, 8(1), 627-636.

Sugiyono. (2017). *Quantitative and Qualitative Research Methods*. Alfabeta.

Sulistiono, H., & Anggra, E. (2017). Sulistiono, H., & Anggra, E. (2017). The Effect of Asset Structure, Company Size, Asset Growth, and Profitability on Capital Structure in Telecommunication Companies on the IDX for the 2013-2015 Period. *Permana*, 8(1), 69-80.